

## **QUAD•DRILL™**

### **NEW LARGER SIZES TO 3-1/4 INCH**

Ingersoll Cutting Tools is pleased to announce the further expansion of the Quad•Drill line of indexable drills. Ingersoll is now offering nine new standard drill sizes, all larger than 2-inch diameter. The new drills are available starting at 2-1/8" diameter. These drills will only be offered in a 2:1 length to diameter ratio at this time.

The new larger diameter Quad•Drill can increase our customers productivity by as much as 30% when compared to the old Ingersoll "A" drills. The new large diameter Quad•Drills further enhance ingersoll's growing reputation for having the best indexable drilling line-up in the market.

These drills utilize the same size quad inserts that you have all come to know and love. each drill is designed with four insert stations. Finally, stock standard Quad•Drills, in larger diameters you've all been craving!

3:1 Lengths coming Soon!



# QUADODRILL™

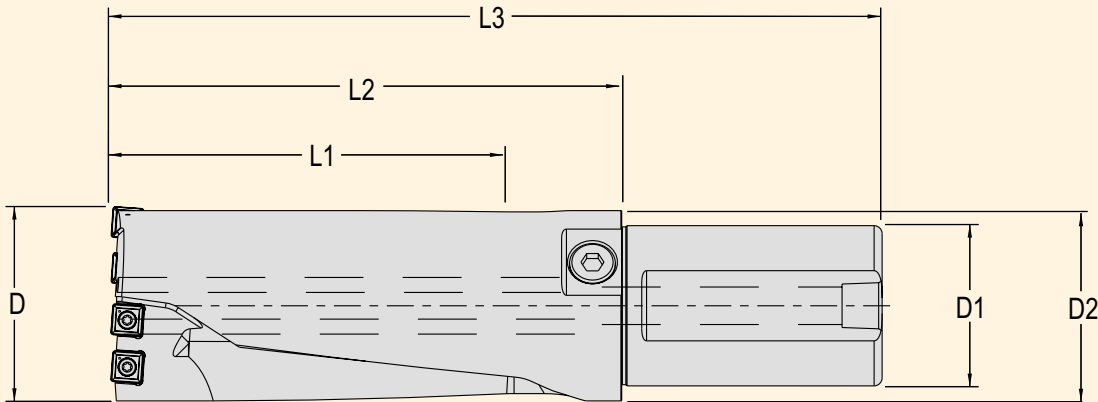

Ingersoll Number	Item #	D	D-mm	L1	L2	L3	D1	D2
Q0539108N8R01	3200001	2.125	54.0	4.25	6.00	9.25	2" Univ	2.36
Q0571114N8R01	3200003	2.250	57.2	4.50	6.00	9.25		
Q0603121N8R01	3200004	2.375	60.3	4.75	6.50	9.75		
Q0635127N8R01	3200005	2.500	63.5	5.00	6.38	9.63		NA
Q0666133N8R01	3200006	2.625	66.7	5.25	6.75	10.00		
Q0698140N8R01	3200007	2.750	69.9	5.50	7.00	10.25		
Q0730146N8R01	3200008	2.875	73.0	5.75	7.25	10.50		
Q0762152N8R01	3200009	3.000	76.2	6.00	7.50	10.75		
Q0825165N8R01	3200010	3.250	82.6	6.50	8.00	11.25		

Ingersoll Number	Item #	Insert Size	Inserts	Insert screw	NPTF
Q0539108N8R01	3200001	SPLT07T308N-PH	4	SM25-064-00	1/4" NPT
Q0571114N8R01	3200003	SHLT090408N-PH	4	SM35-088-60	
Q0603121N8R01	3200004	SHLT090408N-PH	4		
Q0635127N8R01	3200005	SHLT090408N-PH	4		
Q0666133N8R01	3200006	SHLT090408N-PH	4		
Q0698140N8R01	3200007	SHLT090408N-PH	4		
Q0730146N8R01	3200008	SHLT110408-PH1	4		
Q0762152N8R01	3200009	SHLT110408-PH1	4		
Q0825165N8R01	3200010	SPLT140512N-PH	4	SM50-122-50	