



U-CENTER

NC heads for facing, boring, threading and radiusing for machining centres



Index

U-CENTER

NC heads for facing, boring, threading and radiusing for machining centres

GENERAL FEATURES	p. 148-149
U-DRIVE	p. 150
ASSEMBLY	p. 151
SIZES	p. 152
CHIP REMOVAL CAPACITY	p. 153
SUPPLY	p. 154
TOOLHOLDERS AND HEADS	p. 155
TECHNICAL DATA	p. 156-157

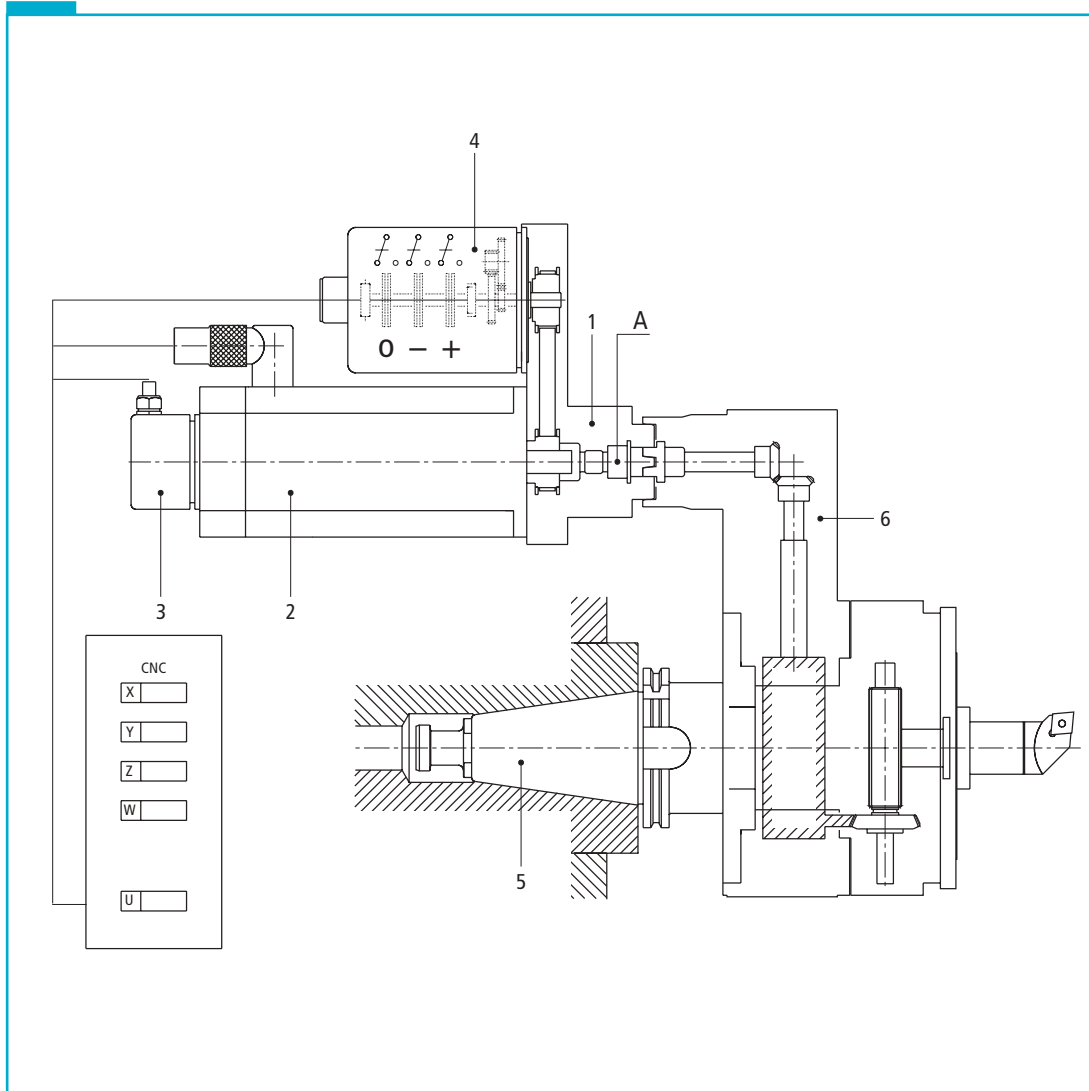

U-CENTER
 U-CENTER boring and facing heads are designed for use on machines with automatic tool change, thus essentially on machining centres. The feed movement of the toolholder slide and the tool position, even during rotation, is controlled by a U-DRIVE motor drive unit. This unit is managed directly by an axis, known as "U", of the machining centre numerical control.

A machining centre set up in this way allows to carry out a series of different tooling procedures such as inner and outer turning, cutting grooves, tapered bores (even variable), concave and convex spokes, cylindrical and tapered threading, phonographic spirals, etc.

1. Power take-off
2. Servomotor
3. Transducer
4. Limit microswitches
5. Arbor
6. U-CENTER head

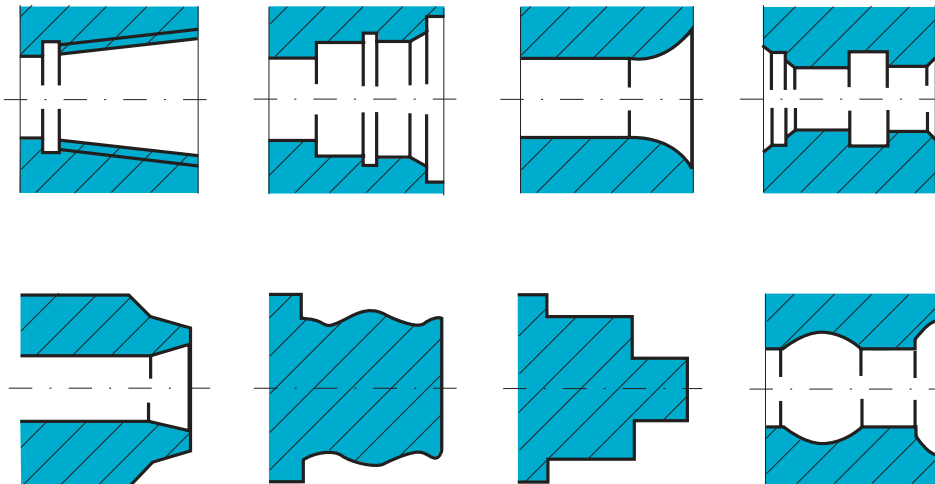

KINEMATIC SYSTEM OF THE U-CENTER

The kinematic system of all U-CENTERS is made up of a differential unit where one revolution of the power take-off "A" corresponds to one 0.25 mm radial shift of the slide. The maximum allowed rate of 2000 RPM at power take-off corresponds to a slide feed speed of 500 mm/min. The rated torque necessary for power take-off is 2 Nm. Between the servomotor mounted in the U-DRIVE unit and the toolholder slide of the U-CENTER is a radial reversal play of approximately 0.05 mm, thus in order to be precise positioning must take place in a single direction, and be included during programming.

COMPONENTS

1. Stationary body
2. Rotating body
3. Tool slide
4. Interchangeable arbor
5. Counterweights
6. Toolholders with interchangeable head
7. Coolant outlets
8. Power take-off 'A'; locking-release system ensures that the rotating body is secured to the fixed body when the U-CENTER is automatically removed from the spindle of the machining centre and placed in the tool magazine.

BALANCING

U-CENTER heads are designed with two counterweights (5) for automatic balancing, which move in the opposite direction to the slide (3) to allow to work at a high RPM without noticeable sways. The balanced heads are especially suited for precision tooling and to create diameters that require high rotation speed.

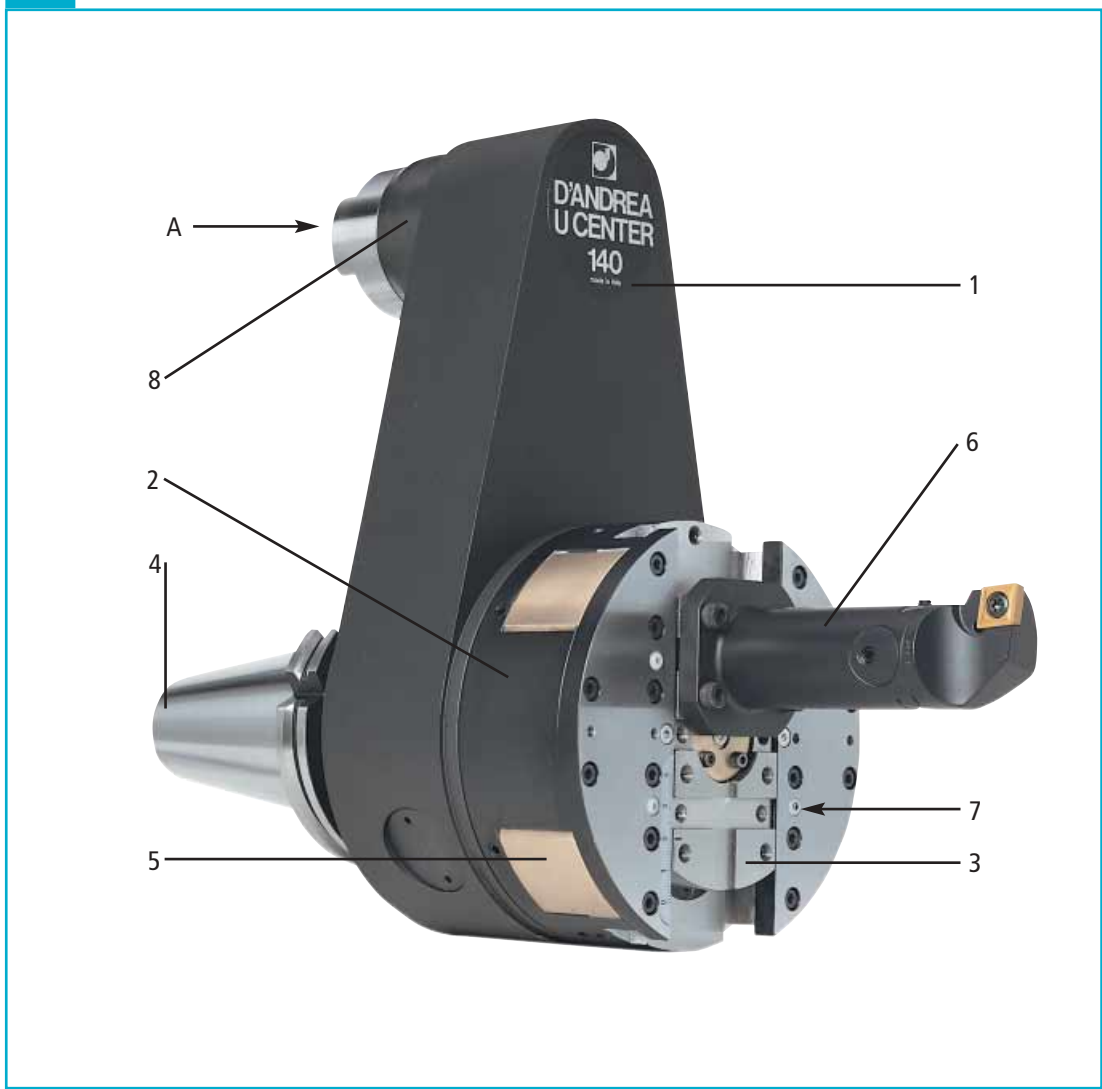

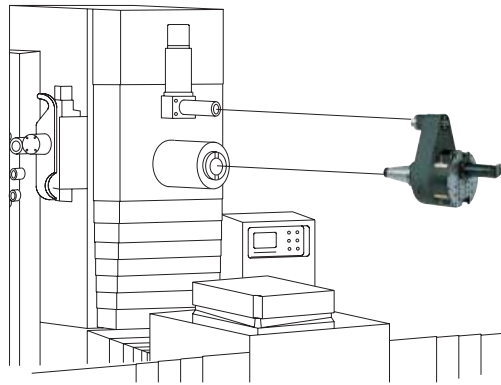

fig. 3

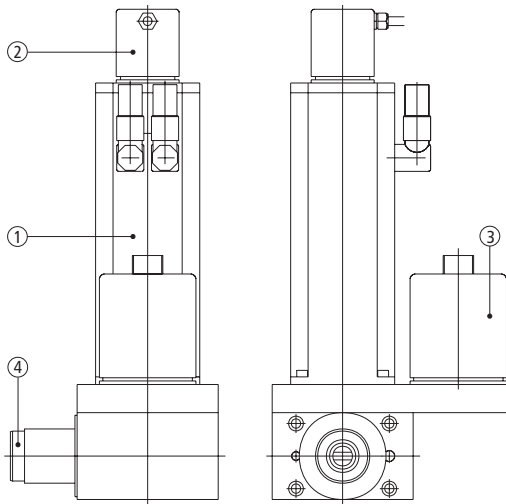

fig. 4

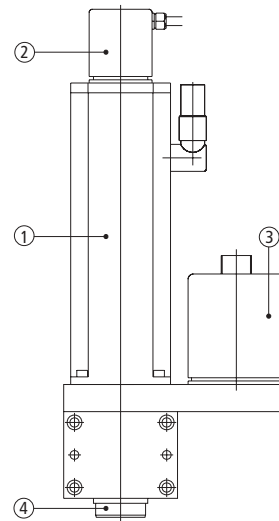
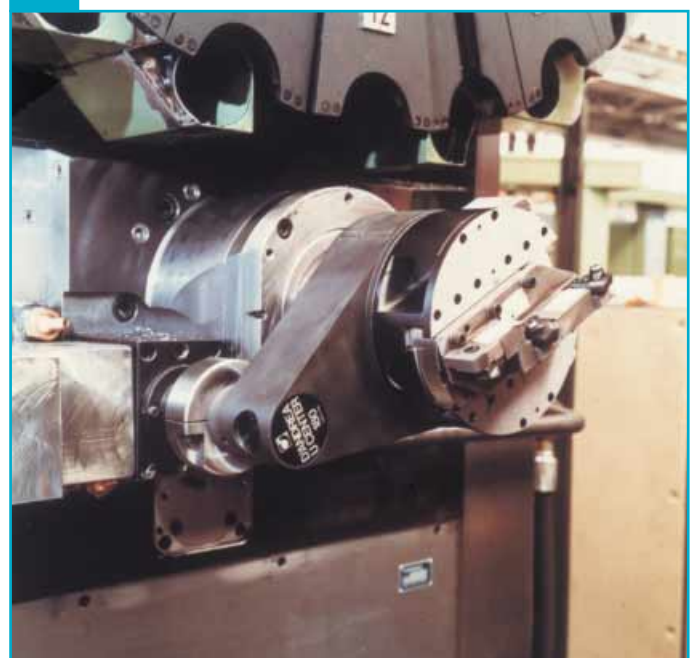

fig. 5

The U-DRIVE unit has to be properly mounted on the machine's headstock to allow for a safe engagement with the U-CENTER head (fig.3). The U-DRIVE unit contains the U axis servomotor (1), a transducer (2), the end of stroke (3), zero reference proximity switches and the drive system to the U-CENTER head. The U-DRIVE can take different patterns according to the application on the machining centre; the most common are: angle (fig.4) or in line (fig.5)



ASSEMBLY

The manufacture and installation of the U-DRIVE must observe the measurements and tolerances indicated on the drawings.

DATA

- 1. Spacer to adapt the U-DRIVE according to the measurement $(X+0.5)$ mm
- 2. Preload spring (max load 20N)
- 3. Air intake for cleaning the power take-off
- 4. Wedge clutch axial stroke from 1 to 2 mm
- 5. Spring (max load 50 N)
- 6. Rotation lock disengage stroke
- 7. Lock-release lever
- 8. Reference peg
- 9. Positioning ring

A. Distance between the taper reference line and the surface of the U-CENTER head

H. Height of the U-CENTER power take-off

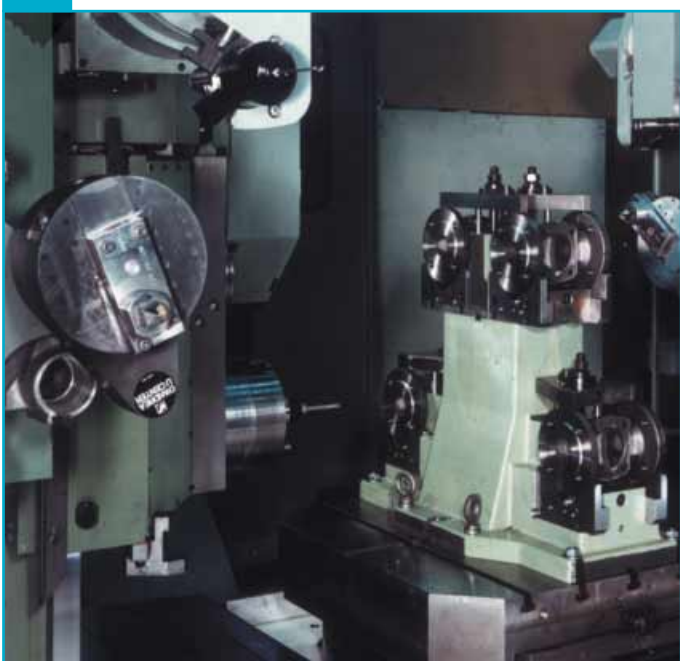
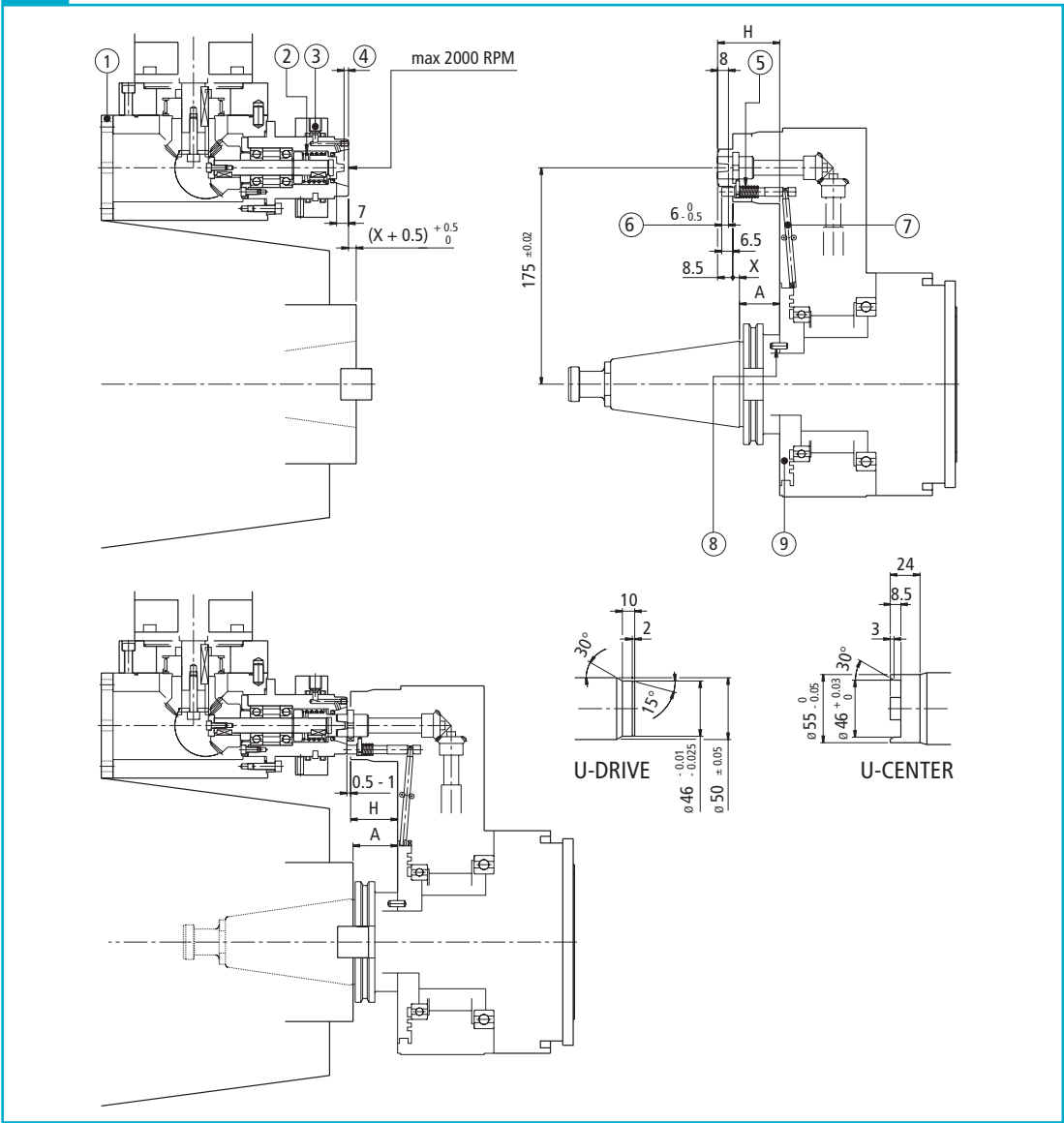

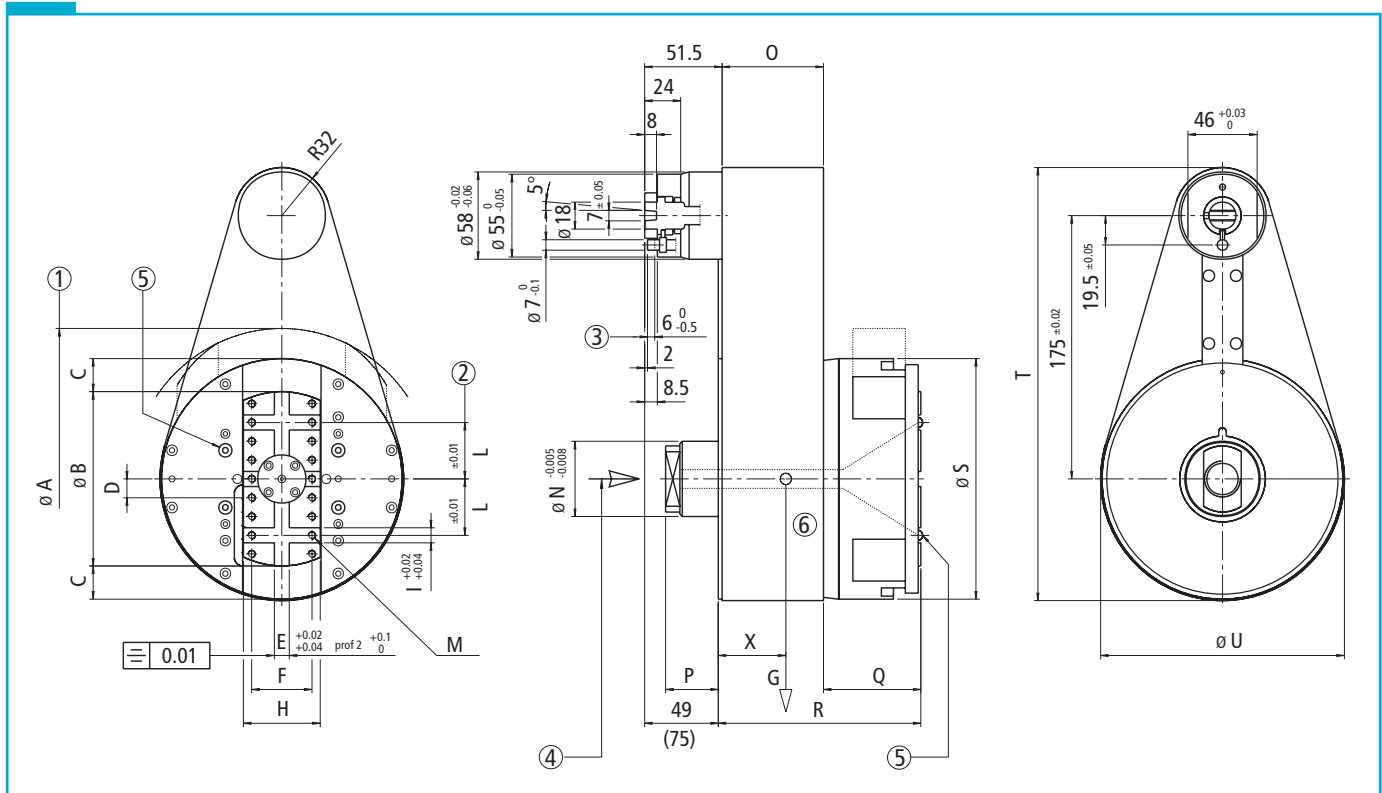

DATA	UC 140 BH	UC 160 BH	UC 180 BH	UC 200 BH
ØA mm	175	200	223	275
ØB mm	100	116	125	200
C mm	20	22.5	25	37.5
D mm	12.5	12.5	15	15
E mm	10	10	12	12
F mm	40	40	50	50
G (da N)	11.7	19	22.5	26.5
H mm	50	51	63	63
I mm	10	10	12	12
L mm	25	37.5	30	60
M mm	n° 14 M 5x11	n° 18 M 5x11	n° 14 M 6x12	n° 26 M 6x12
ØN mm	40	50	50	50
O mm	55	67.5	67.5	67.5
P mm	29.5	35	35	35
Q mm	59.5	63.5	73	73
R mm	117	133.5	143	143
ØS mm	140	160	180	200
T mm	278	288	298	298
ØU mm	142	162	182	182
Xmm	55	65	74	85

DATA

1. Maximum overall dimensions of balancing weights
2. Measurements for hollows
3. Rotation lock disengage stroke
4. Coolant intake
5. Coolant outlet
6. Centre of gravity

These parameters are indicative for normal working conditions on steel with a hardness of 160-200 HB, positive insert and cutting speed of 120 m/min.

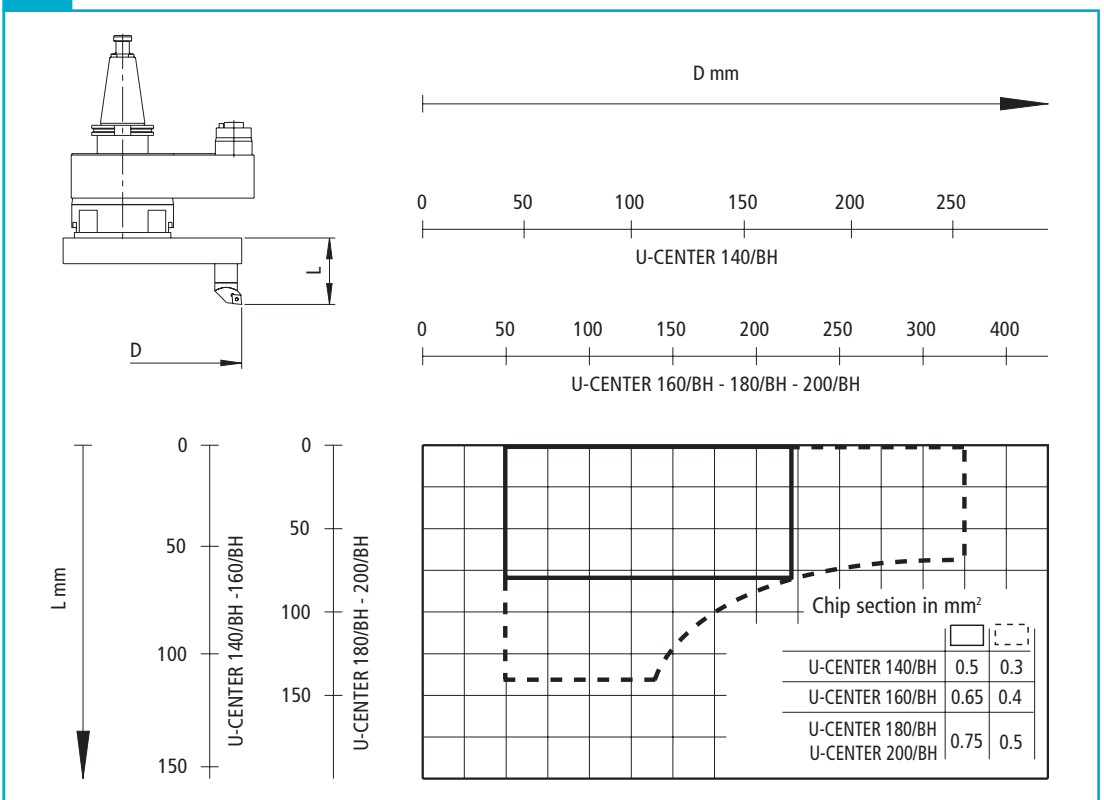
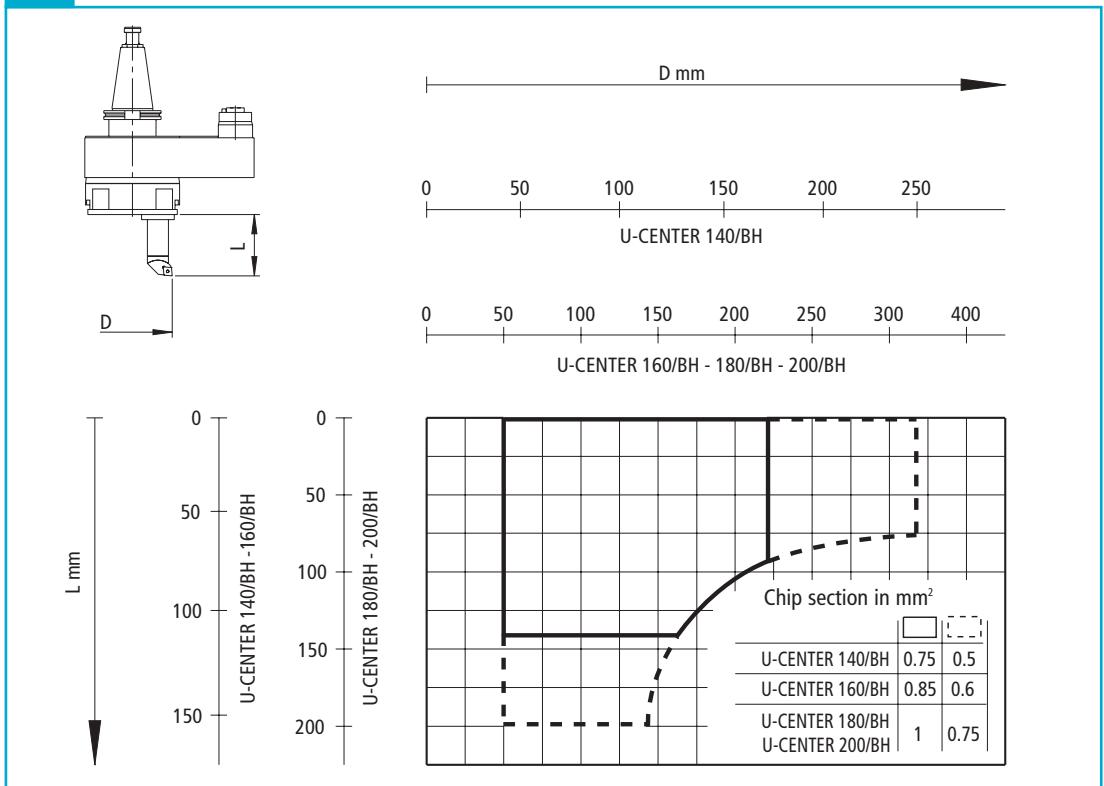

K02

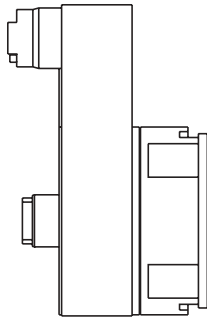

REF.	K02 UC 140/BH	K02 UC 160/BH	K02 UC 180/BH	K02 UC 200/BH
CODE	50 04 142 02 300	50 04 162 02 300	50 04 182 02 300	50 04 202 02 300

K03

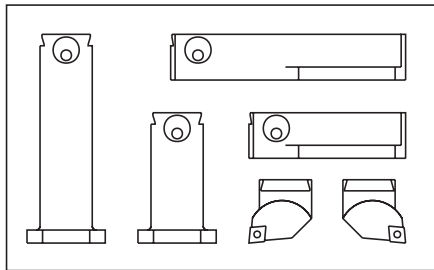

consisting of:

- | | |
|-------|---------|
| P 100 | P 111 |
| P 101 | T 214 L |
| P 110 | T 214 R |

REF.	K03 UC 140/BH	K03 UC 160/BH	K03 UC 180/BH	K03 UC 200/BH
CODE	50 04 142 03 000	50 04 142 03 000	50 04 182 03 000	50 04 182 03 000

ARBORS

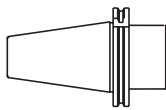

To order the U-CENTER arbor, it is necessary to draw-up the form on p. 156

REF.	UC 140/BH	UC 160/BH	UC 180/BH	UC 200/BH
	ISO 45 / 50	ISO 45 / 50	ISO 45 / 50	ISO 45 / 50

**P100
P101**

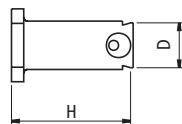

	REF.	CODE	D	H
UC 140 - 160/BH	P 100	43 15 50 32 080 1	32	80
	P 101	43 15 50 32 125 1		125
UC 180 - 200/BH	P 100	43 15 60 40 100 0	40	100
	P 101	43 15 60 40 160 0		160

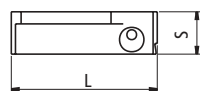

**P110
P111**



	REF.	CODE	S	L
UC 140 - 160/BH	P 110	43 35 50 32 095 0	30	95
	P 111	43 35 50 32 140 1		140
UC 180 - 200/BH	P 110	43 35 60 40 120 0	35	120
	P 111	43 35 60 40 180 0		180

**T 214L
T 214R**



	REF.	CODE	A	D	F			
UC 140 - 160/BH	T 214 L	46 02 032 12 9 10	30	32	22	CCMT 1204..	49 40 1 0005009	10 150 09 0250 0
	T 214 R	46 02 032 12 9 20						
UC 180 - 200/BH	T 214 L	46 02 040 12 9 10	40	40	28	CCMT 1204..	49 40 1 0005009	10 150 09 0250 0
	T 214 R	46 02 040 12 9 20						

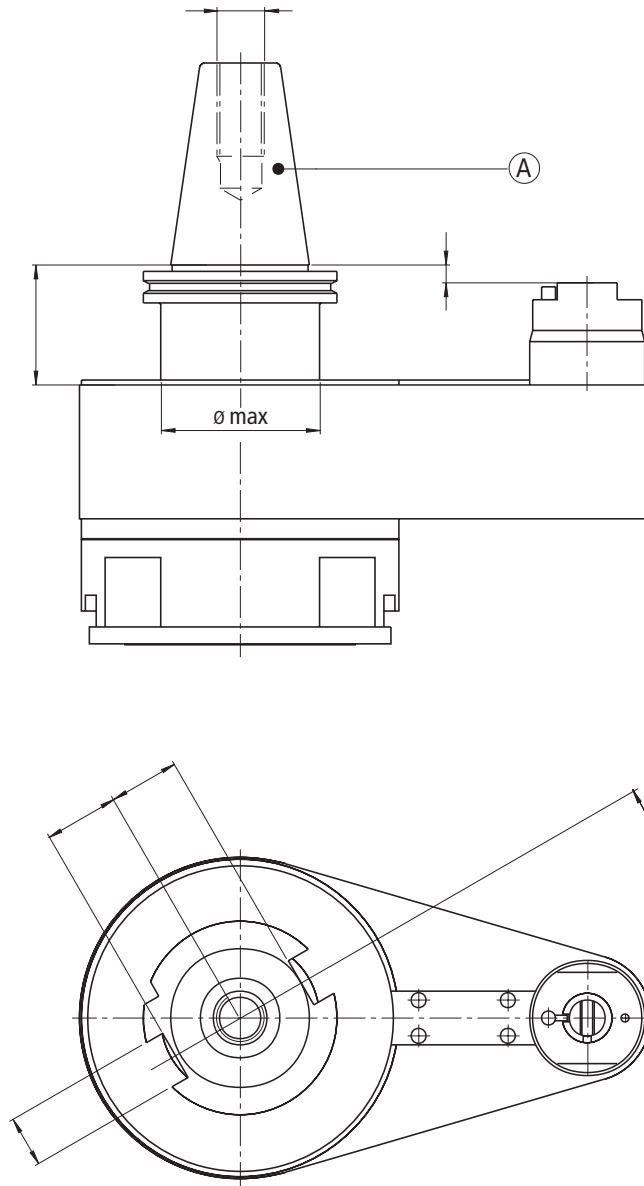

To order the U-CENTER supplied with arbor (A) it is necessary to enclose a filled copy of the following design, or the application layout.

REQUESTED DATA

U-CENTER mod.: _____

Type of arbor (A): _____

MACHINING CENTRE

Trademark: _____

Model: _____

Spindle: _____

Max. tool weight: _____

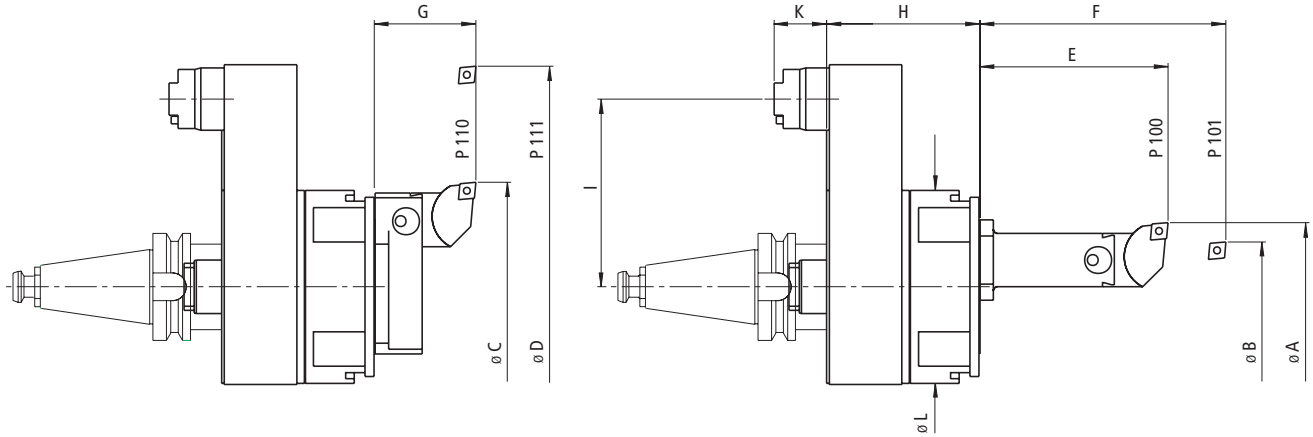

TECHNICAL DATA			UC 140 BH		UC 160 BH		UC 180 BH		UC 200 BH	
H	mm	inch	117	4.60"	133.5	5.25"	143	5.62"	143	5.62"
K	mm	inch	49	1.93"	49	1.93"	49	1.93"	49	1.93"
I	mm	inch	175	6.89"	175	6.89"	175	6.89"	175	6.89"
L	mm	inch	140	5.5"	160	6.3"	180	7"	200	7.87"
Tool slide trasverse	mm	inch	40	1.57"	45	1.77"	50	1.97"	75	2.95"
Feed	mm/min.	inch/min.	1÷500	.04"÷19.68"	1÷500	.04"÷19.68"	1÷500	.04"÷19.68"	1÷500	.04"÷19.68"
Rapid motion	mm/min.	inch/min.	500	19.68"	500	19.68"	500	19.68"	500	19.68"
Maximum speed	RPM	RPM	1200	1200	1200	1200	1000	1000	600÷800	600÷800
Torque	Nm	lb ft.	600	444	800	592	1000	740	1000	740
Max. torque on take-off shaft	Nm	lb ft.	1.5	1.11	2	1.48	2	1.48	2	1.48
Radial force	daN	pound	150	337.5	200	540	250	562.5	250	562.5
Unidirec. repeatability accuracy RP	mm	inch	0.005	.0002"	0.005	.0002"	0.005	.0002"	0.005	.0002"
Weight with shank	Kg	pound	15	33.75	22	49.5	27	60.75	31	69.75
Ø A	mm	inch	125	4.92"	160	6.3"	160	6.3"	180	7"
Ø B	mm	inch	100	3.94"	125	4.92"	125	4.92"	140	5.5"
Ø C	mm	inch	180	7"	200	7.87"	220	8.66"	250	9.84"
Ø D	mm	inch	250	9.84"	300	11.8"	320	12.6"	350	13.78"
E	mm	inch	110	4.33"	110	4.33"	140	5.5"	140	5.5"
F	mm	inch	155	6.1"	155	6.1"	200	7.87"	200	7.87"
G	mm	inch	60	2.36"	60	2.36"	75	2.95"	75	2.95"
Boring accuracy			H7	H7	H7	H7	H7	H7	H7	H7
Facing accuracy on tot. slide stroke	mm	inch	0.01	.00039"	0.01	.00039"	0.01	.00039"	0.01	.00039"
Max. chip removal on C40 steel										
Facing	mm ²	inch ²	0.5	.00078"	0.6	.00094"	0.75	.00117"	0.75	.00117"
Boring	mm ²	inch ²	0.75	.00117"	0.85	.00133"	1	.00156"	1	.00156"
Roughness	Ra	µin	1.6	63"	1.6	63"	1.6	63"	1.6	63"

